

!WARNING!

SPACE BETWEEN DOOR AND HOISTWAY MUST NOT EXCEED 3"

INTERLOCKS CONFORMING TO ASME A17.1 MUST BE INSTALLED AND ADJUSTED PER THE MANUFACTURER'S INSTRUCTIONS.

!FAILURE TO COMPLY MAY RESULT IN SERIOUS INJURY OR DEATH!

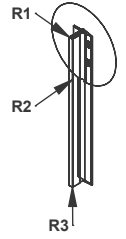
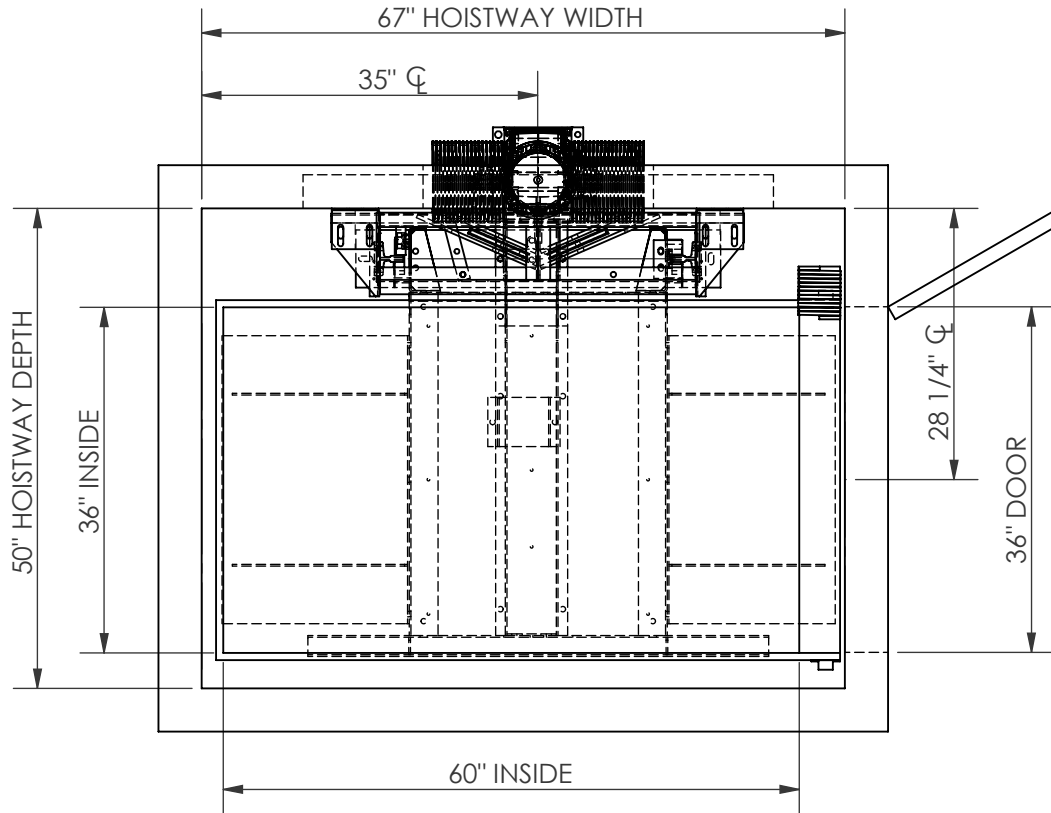
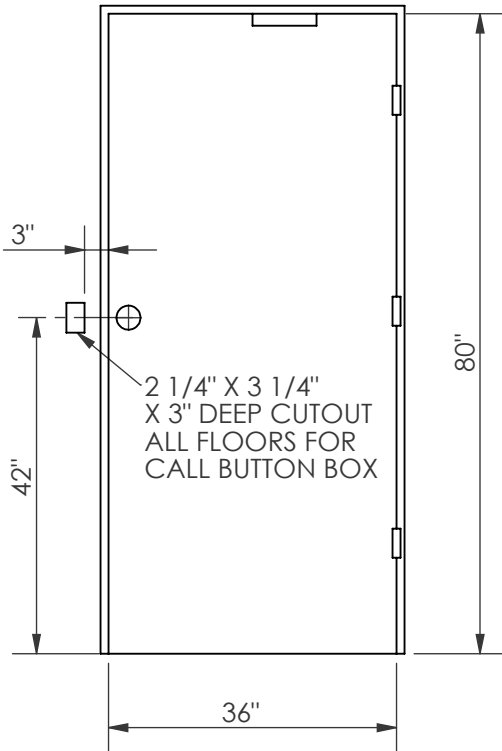
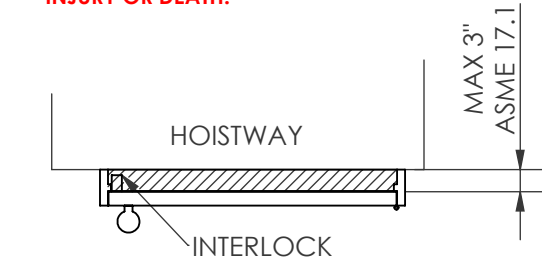

RAIL WEIGHT: 8 lbs/ft

RAIL FORCES

*R1(Fx) 1075 lbs

*R2(Fy) 358 lbs

R3(Fz) 2500 lbs

SIZE	 <i>America's leader in home elevators.</i>
A	
PART NO.	36 X 60, 1R
SHEET 1 OF 3	
DESCRIPTION:	SWING DOORS, BASEMENT DRUM

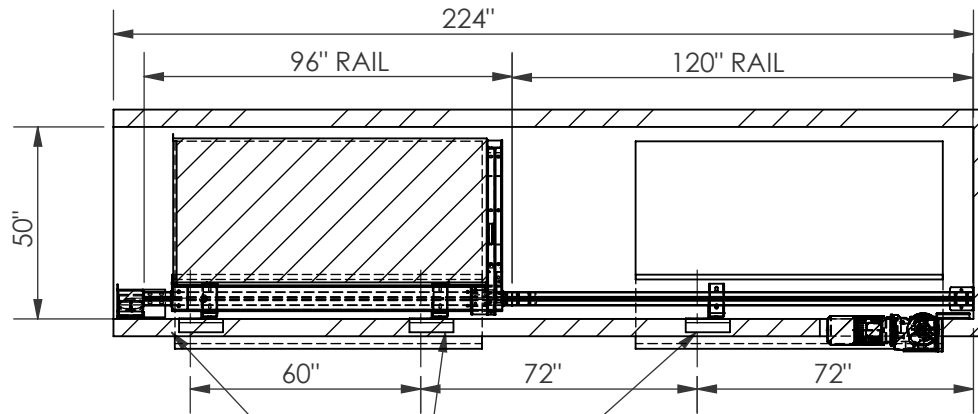

BRACKET LOCATIONS MAY VARY
ACCORDING TO TRAVEL

PROVIDE WALL CONSTRUCTION
SUITABLE FOR ATTACHMENT OF
RAIL BRACKETS AT SHOWN ELEVATION.
MUST BE CAPABLE OF 300LB PULLOUT
LOADING WITH MAX DEFLECTION OF 1/8\".

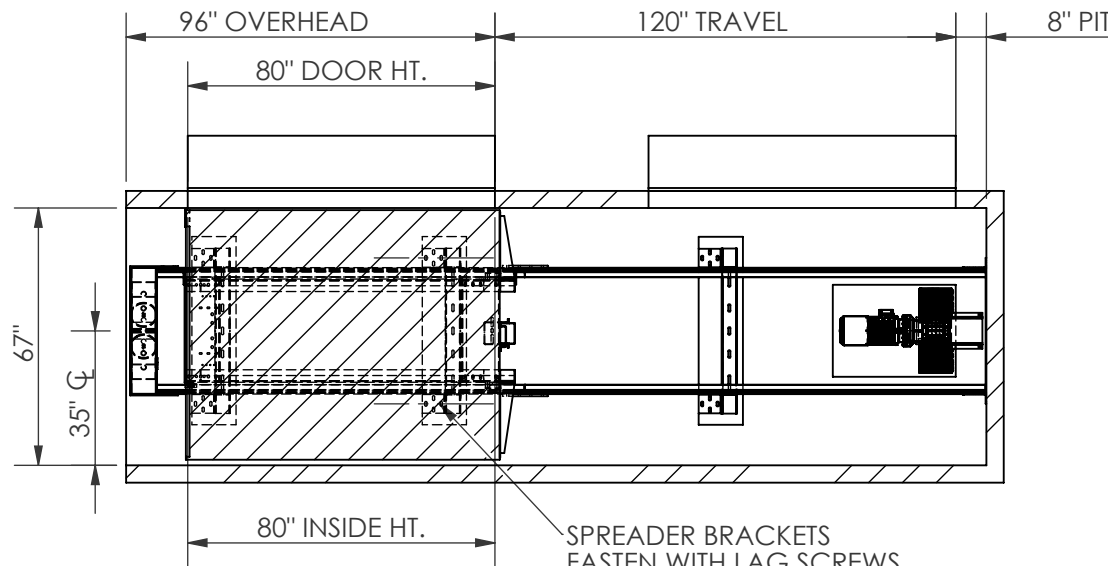

SPREADER BRACKETS
FASTEN WITH LAG SCREWS
2 PLACES PER SIDE BRACKET

SIZE A	 America's <i>leader</i> in home elevators.
------------------	---

PART NO.
36 X 60, 1R
SHEET 2 OF 3
DESCRIPTION:
SWING DOORS, BASEMENT DRUM

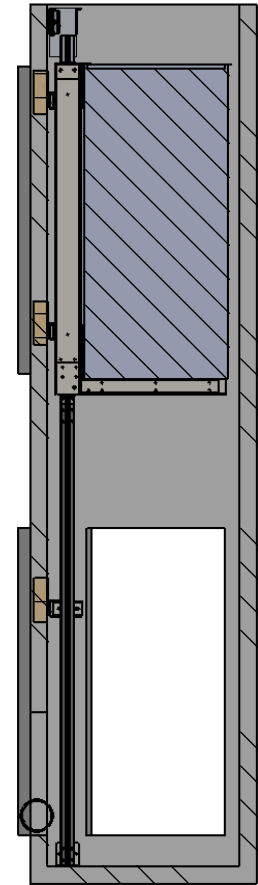
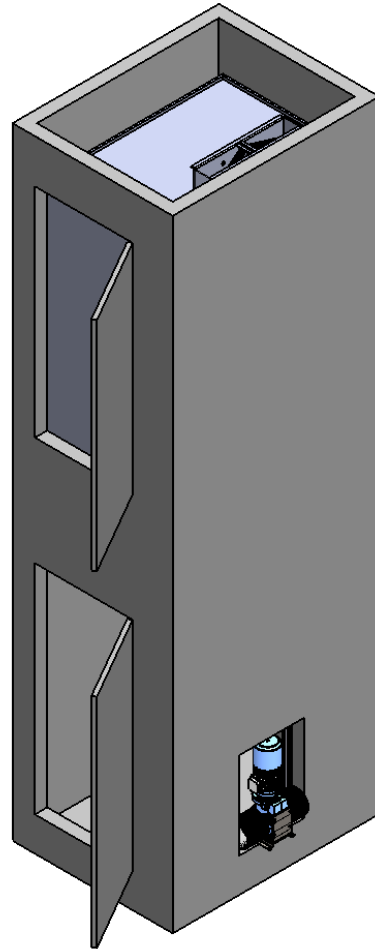
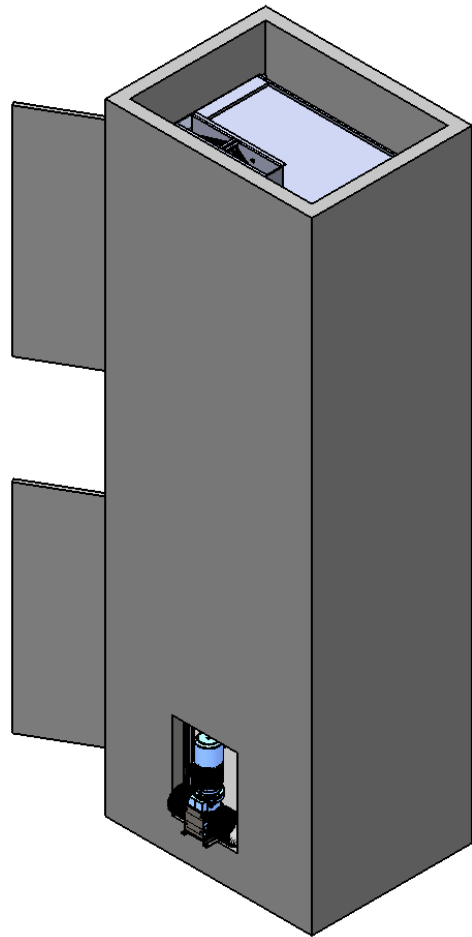

SIZE	 Nationwide Lifts <i>America's leader in home elevators.</i>
A	
PART NO.	36 X 60, 1R
	SHEET 3 OF 3
DESCRIPTION:	SWING DOORS, BASEMENT DRUM

5



4

3

2

1